

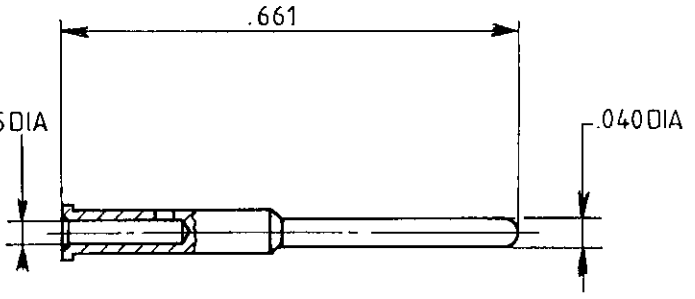

TITRE : SIZE 5 COAXIAL SOCKET CONTACT ENVIRONMENTAL  
FOR RG 58 KX15 & RG 141 CABLES

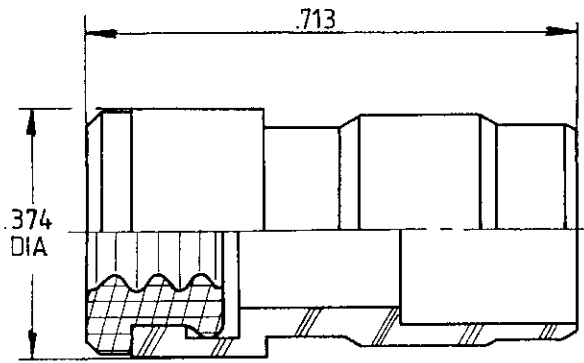

CABLE STRIPPING

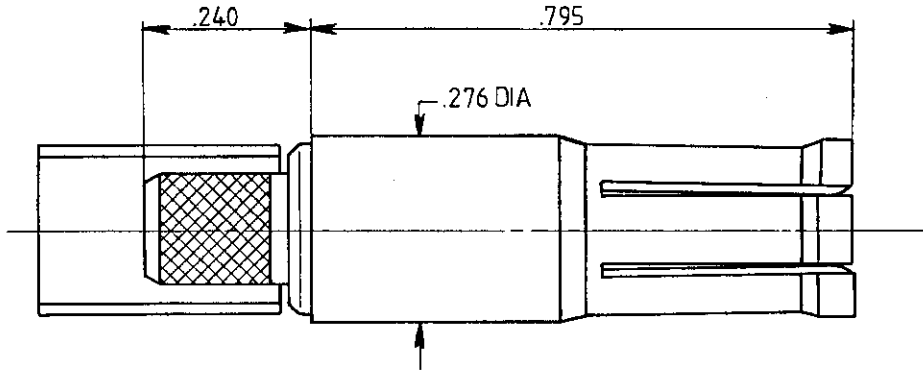
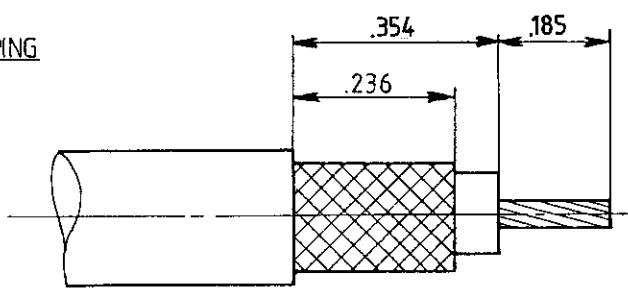

WIRING

CENTER CONTACT:

CRIMPING TOOL : M22520/2\_01 (RADIALL 282 281)      SELECTOR 6 FOR RG58 AND KX15  
8 FOR RG141

POSITIONER : DANIELS K345 (RADIALL 282550)

OUTER CONTACT :

CRIMPING TOOL : M 22520/5\_01 (RADIALL 282 293)  
DIES : M22520/5\_05 (RADIALL 282246) HEX.: A (.213/FLATS)  
OR M22520/5\_45 (RADIALL 282236) HEX.: B (.217/FLATS)

	.315 → .354; .157 → .185; Addition M22520/5_45	28/9/89	Baldyrou
IND	MODIFICATIONS	DATE	VISA

Création      Date      30\_1\_89  
Mise à jour      Date      28/9/89

*Ces renseignements vous sont donnés à titre indicatif. Dans le but constant d'améliorer nos produits, nous nous réservons le droit d'apporter toutes modifications jugées utiles.*



101, Rue Ph. Hoffmann - Z.I. Ouest  
93116 ROSNY/S/B015 Cedex (France)  
Tel. : (1) 48 54 80 40  
Fax : (1) 48 54 63 63  
Telex: Radia A 220673 F